

Bu Çizim MESA OTO ELEKTRİK LTD.ŞTİ'nin malıdır. Şirket Yetkililerinin izni olmaksızın kopya edilemez, üzerinde değişiklik yapılamaz.
This Drawing MESA AUTO ELECTRIC LTD.'s are property. Can not be copied without the consent of the company authorized, any changes can be made.

PARÇA KODU PART CODE	PARÇA ADI PART NAME	s ÖLÇÜSÜ (KALINLIK) s MEASURE (THICKNESS)	Malzeme Material	Kaplama / Coating		
				SN	AG	Ni
TK 2803 RP	3 NO KABLO VE BAKIR SIKAN =RP=	0.3±0.05	(CuZn30) Pirinç / Brass	-	-	-
TK 2803 RPK	3 NO KABLO VE BAKIR SIKAN =RPK=	0.3±0.05	(CuZn30) Pirinç / Brass	+	-	-
TK 2803RÇN	3 NO KABLO VE BAKIR SIKAN =RÇN=	0.3±0.05	Nikel kaplı çelik / Nickel plated Steel	-	-	+
TK 2803.40 RP	3 NO KABLO VE BAKIR SIKAN (0.40 malzeme) =RP=	0.4±0.05	(CuZn30) Pirinç / Brass	-	-	-

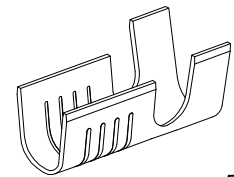

Perspektif
Perspective

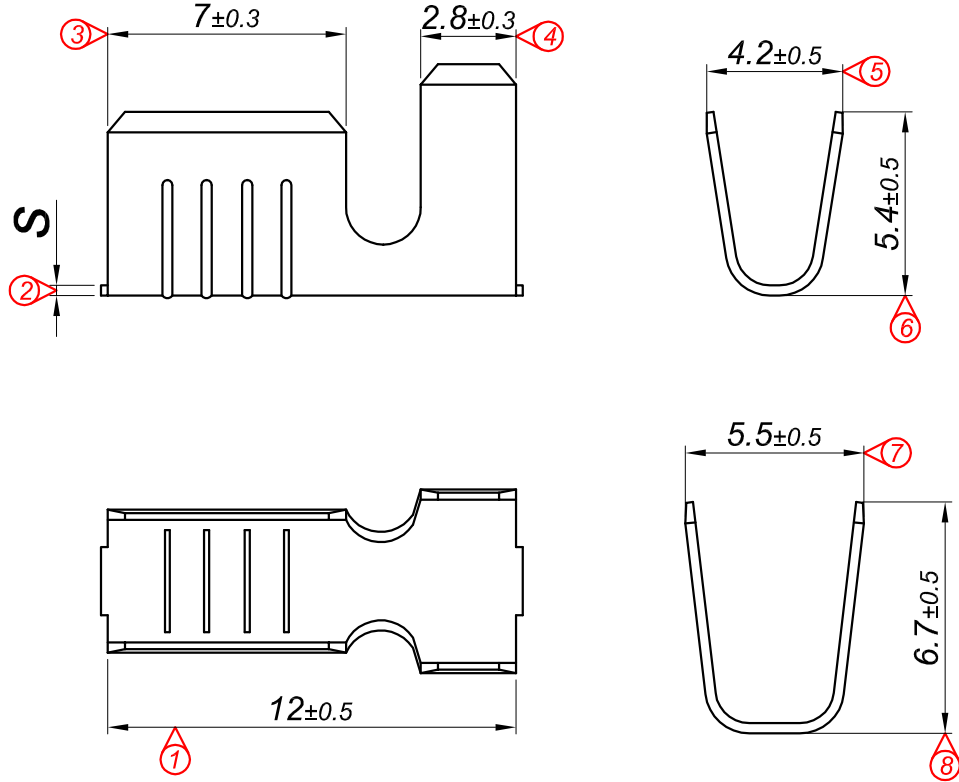
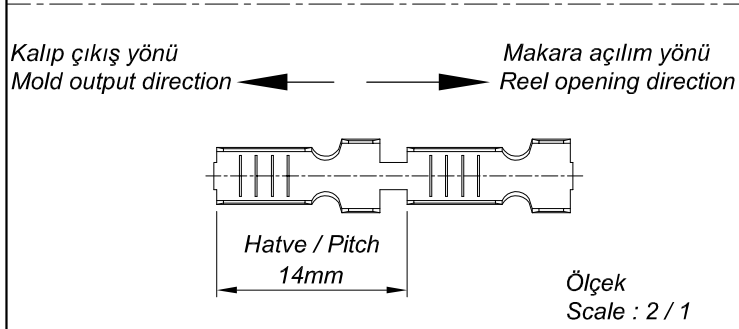

Kablo Kesiti
Wire Section : 2.5 - 4 mm²

Resim üzerinden ölçü almayınız
do not measure on drawing

Tarih / Date	11.11.2013	İmza /Signature	Ölçek / Scale		
Çizen / Desing	M.Yağcı		5 / 1		
Onay / Approval	S.Gölcük			No	Değişiklik / Revision
	Parça Adı: Part Name	3 NO KABLO VE BAKIR SIKAN	Parça Kodu: Part Code	TK 2803	